

# LOGSET Harvester Head



# TH75

# TH75X

## Perfect match to Logset 8H harvesters

The heavy duty Logset TH75 is the third largest head of the Logset TH range.

It has a relatively short frame and weighs only 1 300 kg, making it a perfect match to Logset 8H harvesters.

The minimum stem-to-frame contact reduces friction, ensuring low fuel consumption and a long lifetime for the components. The Logset TH75 is a complete solution for heavy trunks. The fixed rear knife increases the delimiting quality. For the best results, Logset offers alternative feeding motor sizes and spikes for the feeding wheels.

Logset TH75X. The strong construction of the Logset TH75X is ideal for track-based machines. It feeds stems effectively even at lower pump and engine power. With two tractive feeding wheels and a support back roller, the construction is robust yet simple.

SIMPLY BETTER

**LOGSET**

# LOGSET Harvester Head

# TH75 / TH75X

## TH75

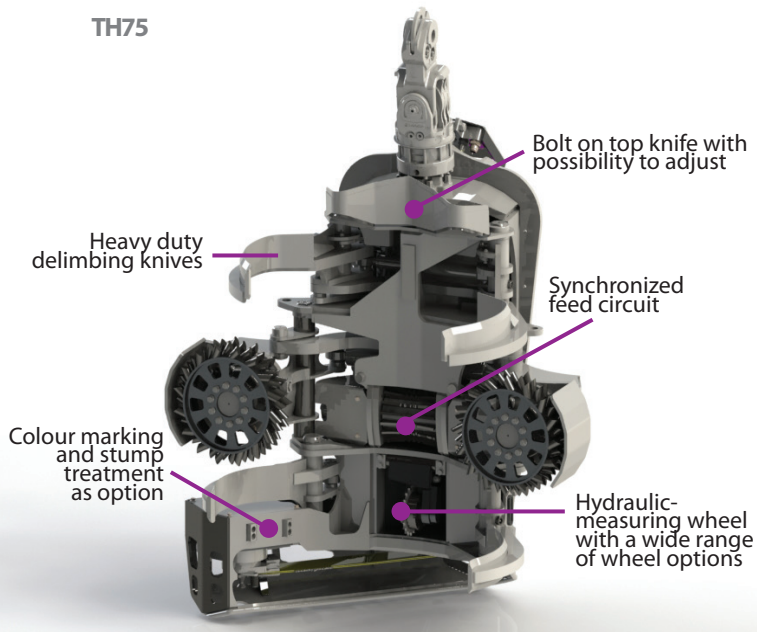

## TH75X

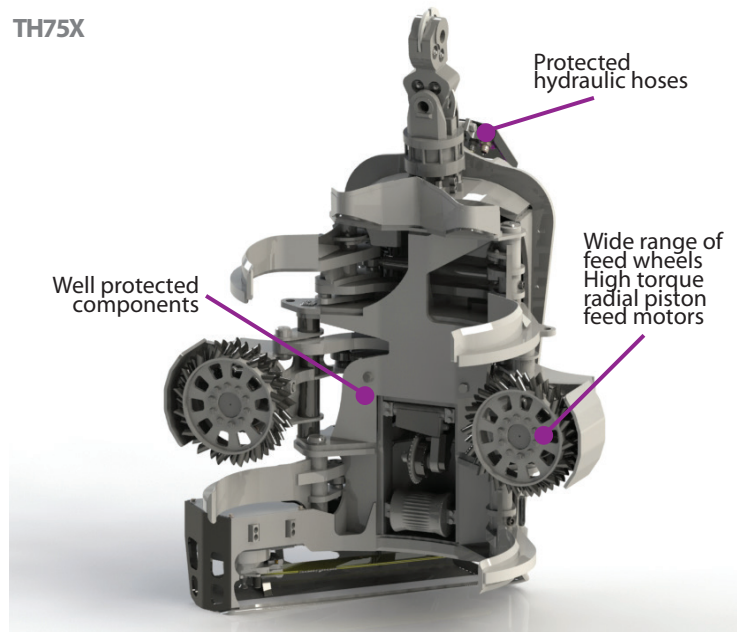

## Technical data

DIMENSIONS		
Width, head open	mm	1700 (67 in)
Width, head closed	mm	1370 (54 in)
Height to top knife	mm	1500 (59 in)
Height with rotator and link	mm	2030 (80 in)
Weight with rotator and link	kg	1400 (3 086 lbs)
FELLING/CUTTING		
Max. felling/cutting diameter	mm	800 (31 in)
Saw bar	mm	900 (35 in)
Saw unit	SuperCut 100 / 150	
Saw motor	Parker F12-19, Bucher 19-20-32 (32 for SuperCut 150)	
Saw chain tensioning	Hydraulic	
Chain oil tank volume	liter	8 (2 gal)
HYDRAULIC SYSTEM		
Max. pressure	bar	280 (4 061 psi)
Flow required for optimal prod.	l/min	300 (79 gal/min)
Valve block: purpose built hydraulic manifold		
FEEDING		
Hydraulic motors, feeding arms	cm <sup>3</sup>	620/820
Hydraulic motors, chassis	cm <sup>3</sup>	315/400
Number of hydraulic motors	pcs	4 / 2 for X model
Feeding speed (300 l/min, 79 gal/min)	m/s	5,6/4,4 (18/14 ft/s)
Max. opening, feed wheels	mm	740 (29 in)

DELIMITING	
Max. opening, upper knives	mm 780 (31 in)
Delimiting diameter tip to tip	mm 480/550 (19/22 in)
Number of static knives	pcs 2
Number of movable knives	pcs 4
ROTATOR	
Indexator AV 17/H182, Black Bruin BBR 16	
MEASURING DEVICE	
Logset TOC-MD 2	
RECOMMENDED BASE MACHINE SIZE	
Wheeled base, from	18-22 t. (40 000-49 000 lbs)
Tracked base, from	19-24 t. (42 000-53 000 lbs)
OPTIONAL EQUIPMENT	

Contact your local dealer for more information about options.

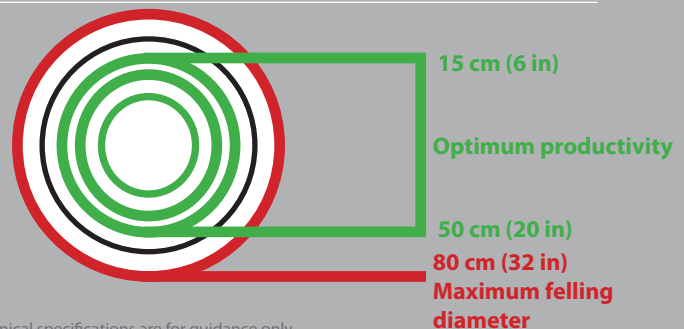

Harvester heads range 12/17 - EN. We reserve the right to make changes without prior notice. All technical specifications are for guidance only. The pictures and diagrams do not always show standard versions of the heads. Copyright Logset Oy.

**Logset Oy**  
 Hännisentie 2  
 FI-66530 Koivulahti  
 FINLAND  
 Tel. +358 10 286 3200

**LICO Pty Limited**  
 18 Graham Road  
 MOUNT GAMBIER SA 5290  
 AUSTRALIA  
 Tel. +61402034573

**LOGSET**  
 SIMPLY BETTER  
[www.logset.com](http://www.logset.com)